



BZ Setup sheet



Date: Aug 7 Place: Hint Racing Track Track: Very Tight
 Driver: Ah Bee Best lap: TQ Final position: A3

Body: Enzo (Trimmed to 29g)
 Wheel Base: 90 / 94 / **98**
 Motor: Atomic 5000KV
 Spur gear: 56
 Pinion gear: 17
 Gear ratio: _____
 Battery: Atomic 360 mAh
 Servo: Atomic MG
 Weight: 176g

Speed controller

Program card setup

1. Running Mode
 1 2 3
2. Low Voltage Cut-Off Threshold
 1 2 3 4 5 6
3. Over-heat Protection
 1 2
4. Neutral Range
 1 2 3
5. Start Mode (Punch)
 1 2 3 4 5 6 7 8 9
6. Maximum Forward Force
 1 2 3 4 5
7. Maximum Reverse Force
 1 2 3 4
8. Maximum Brake Force
 1 2 3 4 5
9. Drag Brake Force
 1 2 3 4 5 6 7 8
10. Initial Brake Force
 1 2 3 4
11. Timing
 1 2 3 4 5 6 7 8

Front

Shim: 0 mm

Spring: Red (BZ-UP010)

Grease: Kyosho 30000

Shim: 0 mm

Arm: N W



Down stop: -1.0

Height: 2.2

Rear

Shim: 0 mm

Spring: Yellow (BZ-UP010)

Grease: Kyosho 30000

Shim: 0 mm

Arm: N W

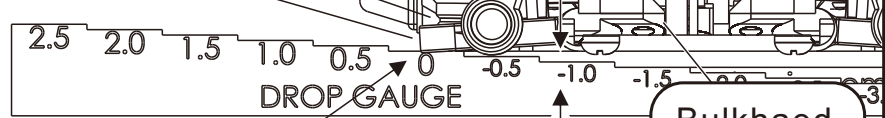

Down stop: -1.6

Height: 2.5

Camber: N W

Ball Diff / Alu. Diff

Ball Diff / Alu. Diff

Camber: N W

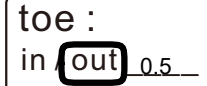
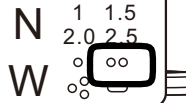

Rear

Front

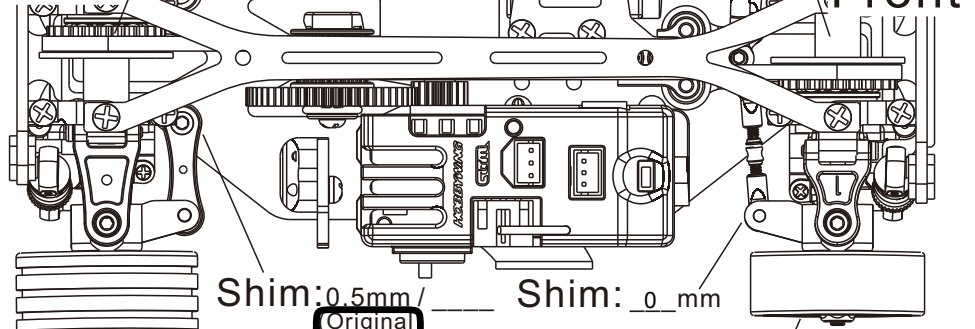

Wheel offset: 0#

Tire: Atomic 7 degree (3 groove)

Wheel offset: 0#

Tire: Atomic 15 AW